

CARTRIDGE PRESSURE REGULATOR

RC

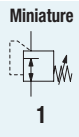

Description	Piston-operated cartridge pressure regulator suitable for assembly block.
Media	compressed air filtered to 50 µm, lubricated or unlubricated
Supply pressure	max. 10 bar
Adjustment	by knurled-head screw with locknut
Relieving function	relieving
Gauge port	not available
Mounting position	any
Temperature range	0 °C to 60 °C / 32 °F to 140 °F, for appropriately conditioned compressed air down to -30 °C / -22 °F
Material	Body: nickel-plated brass Elastomer: NBR/Buna-N

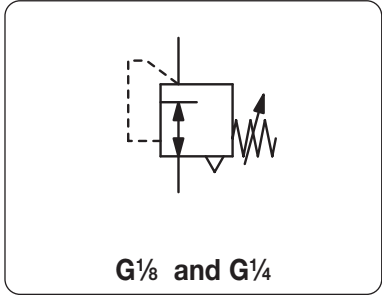

Dimensions				Flow rate	Supply pressure	Connection thread	Pressure range	Order number
A	B	C	A/F					
mm	mm	mm	mm	l/min*1	max. bar	G	bar	

Cartridge regulator					supply pressure max. 10 bar, relieving, without constant bleed	RC
15	57	15	14	150	10	G ¹ / ₈ 1...8 bar RC-01C
19	63	18	17	260	10	G ¹ / ₄ 1...8 bar RC-02C



Step drill for cartridge seat				RCS
16	-	-	-	G ¹ / ₈ RCS-01
20	-	-	-	G ¹ / ₄ RCS-02

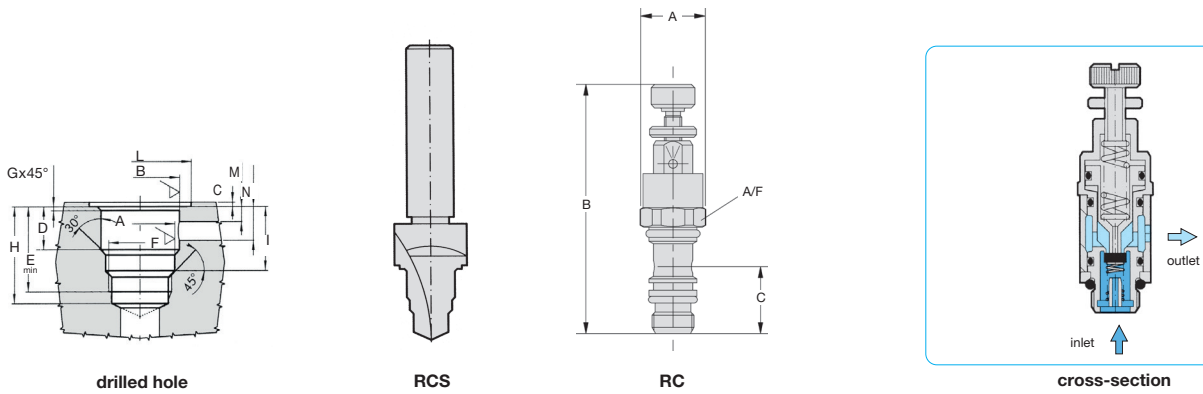

drill	F	A	B	C	D
RCS-01	1/8	9.8 - 0.1/-0	11.2 ± 0.05	0.5 ± 0.5	15.6 ± 0.07
RCS-02	1/4	13.5 + 0.1/-0	14.4 ± 0.05	0.5 ± 0.5	17.5 ± 0.07

drill	E	G	H	I	L	M	N
RCS-01	24.6	0.3	27	18.1 ± 0.2	15.4	3.5	12
RCS-02	28	0.4	31.2	20.8 ± 0.2	19.4	3.5	13.5

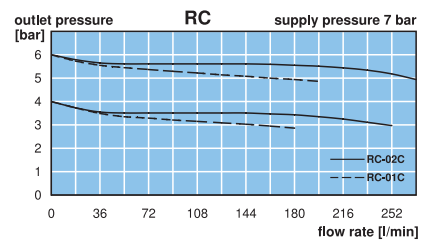

*1 at 7 bar supply pressure, 6 bar outlet pressure and 1 bar pressure drop

* Product group

PDF CAD
www.aircom.net

Order example:
RC-01C